

**PALLET FLOW, PUSHBACK,
DRIVE-IN, DRIVE-THRU
RACKING QUOTATION REQUEST FORM**

DATE:

SPACE



43 Regan Road
Brampton, Ontario
L7A 1B2
Phone: 905.840.5550
Fax: 905.840.5560

MANUFACTURING

CUSTOMER NAME:

ADDRESS:

CITY:

PROVINCE:

PHONE:

FAX:

LOCATION OF INSTALL:

DISTRIBUTOR:

SALES REP.:

PHONE/EMAIL:

- PUSHBACK
- PALLET FLOW
- DRIVE-IN
- DRIVE-THRU

PRODUCT TO BE STORED: _____

PRODUCT FACE: _____ WEIGHT PER PALLET: _____ LBS.

PRODUCT DEPTH: _____ IF THE LOAD OVERHANGS THE PALLET PLEASE ADVISE:

PRODUCT HEIGHT: _____ LOAD OVERHANG FRONT TO BACK: _____ LOAD OVERHANG SIDE TO SIDE: _____

IS THE PALLET STRETCH WRAPPED: Y / N TYPE OF SKID; SEE CHART->: _____

CAN PALLETS BE TURNED TO OTHER FACE: Y / N QUANTITY AND SIZE OF BOTTOM BOARDS: _____

IN A DRIVE-IN OR DRIVE-THRU SCENARIO CAN THE PALLETS BE DOUBLE STACKED ON THE FLOOR: Y / N

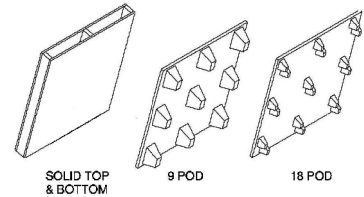
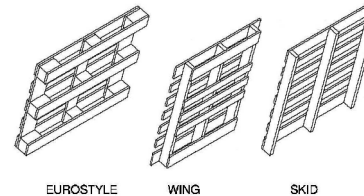
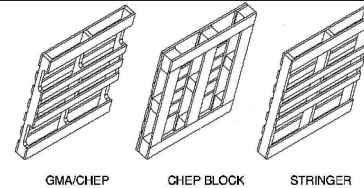
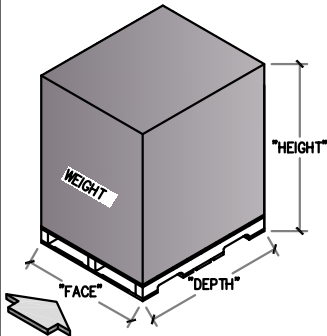

LIFT TRUCK TYPE: _____

MAXIMUM LIFT HEIGHT: _____

MINIMUM AISLE REQUIREMENT: _____

MAXIMUM CAPACITY: _____

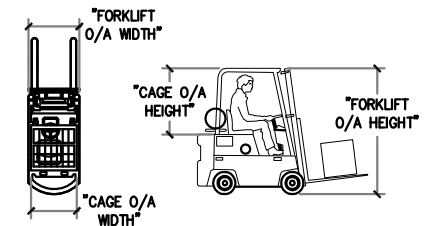

FOR DRIVE-IN OR DRIVE THRU SYSTEMS PLEASE ADVISE THE FOLLOWING:

FORKLIFT O/A HEIGHT: _____ FORKLIFT O/A WIDTH: _____

CAGE O/A HEIGHT: _____ CAGE O/A WIDTH: _____

- APPLICATION:
- INDOOR
 - OUTDOOR
- FOUNDATION:
- CONCRETE
 - OTHER: _____
- STORAGE:
- RAW MATERIAL
 - FINISHED GOODS

- WAREHOUSE:
- FREEZER
 - COOLER
 - AMBIENT
 - WET OR WASH-DOWN
 - DIRTY (WHY?): _____

SYSTEM REQUIREMENTS		
NUMBER OF PALLETS DEEP	NUMBER OF BAYS	NUMBER OF LEVELS
<input type="text"/>	<input type="text"/>	<input type="text"/>

BUILDING UNDER CLEAR:

OBSTRUCTION UNDER CLEAR:

(EG. PIPE, HEATER, ECT)

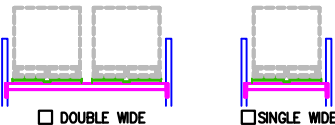

****FOR PUSHBACK PLEASE ADVISE PREFERENCE SINGLE WIDE OR DOUBLE WIDE. PALLET FLOW, DRIVE-IN AND DRIVE-THRU WILL BE SINGLE WIDE.**

NOTE: ON THE CHART PLEASE INDICATE PICKING FACE WITH AN ARROW

**IF PALLET IS STEEL, PLASTIC OR OTHER PLEASE PROVIDE SKETCH AND INDICATE PICKING FACE

PALLET CONDITION:

- CONSISTENTLY GOOD QUALITY
- OCCASIONAL DISFORMITY
- POOR QUALITY (EG. BROKEN BOARDS)

ADDITIONAL NOTES: _____